



Electrolux
PROFESSIONAL

**Modular Cooking Range Line
700XP Electric Chip Scuttle**

ITEM # _____

MODEL # _____

NAME # _____

SIS # _____

AIA # _____



371086 (E7CSEDC000)

Electric chip scuttle top with
1 well

Short Form Specification

Item No. _____

Heating via infrared heating elements positioned on the back of the unit. Perforated false bottom GN 1/1 specially shaped for easier food collection. One piece pressed worktop in 1.5 mm thick stainless steel. Easy to use control panel with ON/OFF switch. Exterior panels in stainless steel with Scotch Brite finish. Right-angled side edges to allow flush-fitting junction between units.

Main Features

- Recommended for use next to a fryer to allow excess oil to drip in the well basin.
- Unit to have infrared heating elements positioned on the back of the unit to keep servings warm until ready to be plated and served.
- Well able to contain 1/1 GN container with a maximum height of 150 mm.
- Easy-to-use control panel.
- Unit supplied with a perforated GN 1/1 false bottom specially shaped for easier food collection.
- All major compartments located in front of unit for ease of maintenance.
- Suitable for countertop installation.

Construction

- One piece pressed 1.5 mm work top in Stainless steel.
- All exterior panels in Stainless Steel with Scotch Brite finishing.
- Model has right-angled side edges to allow flush fitting joints between units, eliminating gaps and possible dirt traps.
- IPX4 water resistance certification.

APPROVAL: _____



Experience the Excellence
www.electroluxprofessional.com



Optional Accessories

- Junction sealing kit PNC 206086
- Support for bridge type system, 800mm PNC 206137
- Support for bridge type system, 1000mm PNC 206138
- Support for bridge type system, 1200mm PNC 206139
- Support for bridge type system, 1400mm PNC 206140
- Support for bridge type system, 1600mm PNC 206141
- Support for bridge type system, 400mm PNC 206154
- Chimney upstand, 400mm PNC 206303
- Right and left side handrails PNC 206307
- BACK HANDRAIL 800 MM - MARINE PNC 206308
- Frontal handrail 400mm PNC 216046
- Frontal handrail 800mm PNC 216047
- Frontal handrail 1200mm PNC 216049
- Frontal handrail 1600mm PNC 216050
- Large handrail - portioning shelf, 400mm PNC 216185
- Large handrail - portioning shelf, 800mm PNC 216186
- 2 side covering panels for top appliances PNC 216277

Front

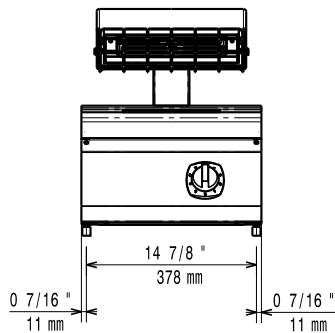

Side

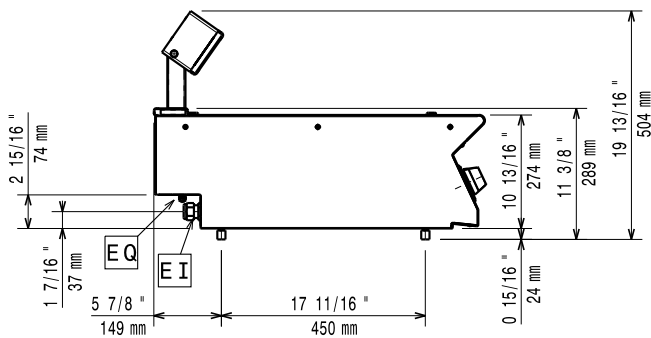

EI = Electrical inlet (power)

Top

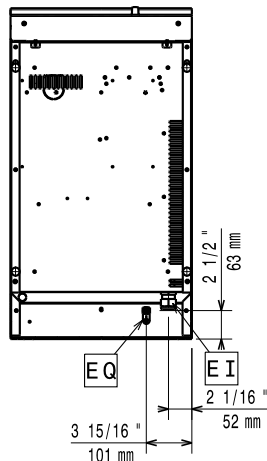

Electric

Supply voltage:	220-230 V/1 ph/50-60 Hz
Predisposed for:	
Electrical power max.:	1 kW
Total Watts:	1 kW

Key Information:

If appliance is set up or next to or against temperature sensitive furniture or similar, a safety gap of approximately 150 mm should be maintained or some form of heat insulation fitted.

Usable well dimensions (width):	306 mm
Usable well dimensions (height):	156 mm
Usable well dimensions (depth):	510 mm
External dimensions, Width:	400 mm
External dimensions, Depth:	730 mm
External dimensions, Height:	250 mm
Net weight:	20 kg
Shipping weight:	27 kg
Shipping height:	650 mm
Shipping width:	460 mm
Shipping depth:	820 mm
Shipping volume:	0.25 m ³
Certification group:	ECS7